

# AIR PREPARATION UNITS

## AIR REGULATOR - series

**Kushako**

### Air Regulator details :

#### Features :

- Suitable for panel & modular mountings.
- Non raising ' Press to Lock ' adjusting knob for locking at any set pressure.
- Diaphragm operated, relieving type.
- Pressure compensated by balanced poppet.
- Good flow & regulating characteristics.

#### Precautions :

- Note the direction of flow before installation & connect pipe accordingly.
- Nipples of taper threads to be used with teflon tape. Ensure teflon tape does not enter the unit during tightening. Nipples of straight threads to be used with sealing washer.
- Flush piping for dirt, dust, rust & other foreign particles.
- Install in clean atmosphere.

#### Technical Specifications:

Model	AR-2016
Medium	Compressed air-Filtered
Port Size	G1/2 BSP ( F )
Pressure gauge port size	G1/4 BSP ( F )
Flow rate ( Ltr / Min )	4000
Maximum supply pr. (bar)	12
Regulating pr. range (bar)	0 - 2, 0 - 4, 0 - 7, 0 - 10 (Standard)
Ambient / Medium temp.	5° - 60° C
Installation	Any position
Materials of construction	Aluminium, Brass, Steel, SS, Nitrile
Optional accessories	Clamp, Modular mounting kit, Pr gauge
Weight (Kg)	0.700

- Supply pressure 7 bar, set pressure drop  $p = 1$  bar (for Standard models) .

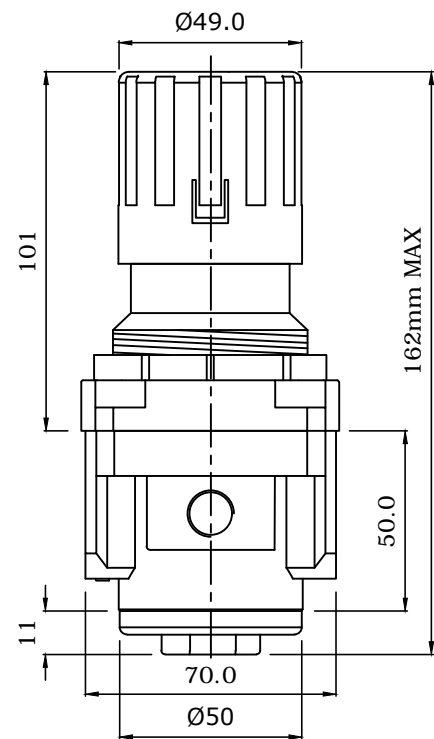

#### Pressure Setting :

Pull the knob & adjust by turning the knob clockwise to increase the pressure. Push the knob back to its lock position. ( Turning the knob counter clockwise will reduce the pressure )

Manufactured by :

***Kushako India***

Office : 490, Narayan Peth, Opp. Pune Marathi Granthalaya, Pune - 411030. (Maharashtra), Website : [www.kushakoindia.com](http://www.kushakoindia.com)

Works : Sr.No. 25/1A, Village Nanded, Sinhgad Road, Tal - Haveli, Dist. Pune -411041

Tel. No : 901169077 / 7620674777

E-mail : [kushako.india@gmail.com](mailto:kushako.india@gmail.com) / [kushakoindia1992@gmail.com](mailto:kushakoindia1992@gmail.com)

**Kushako**